

# Copeland KCE444HAG hermetic compressor

Category: Refrigeration

written by [www.mbsmpro.com](http://www.mbsmpro.com) | December 31, 2025



**Mbsmpro.com, Compressor, KCE444HAG, 3/8 Hp, Copeland, R134a, 230V 50Hz, High / Medium temperature, Water cooler applications**

## Overview of the Copeland KCE444HAG compressor

The **Copeland KCE444HAG** is a hermetic reciprocating compressor designed for high and medium temperature commercial refrigeration using R134a refrigerant.

It is widely used in water coolers and bottle coolers where stable performance, compact size, and low noise are required.

## Technical specifications and operating range

The KCE444HAG belongs to the KCE family and uses a connecting-rod type reciprocating mechanism with a single-phase induction motor.

Its evaporating temperature range is approximately  $-17.8^{\circ}\text{C}$  to  $+12.8^{\circ}\text{C}$ , covering typical high / medium temperature applications in beverage and water cooling.

### Main electrical and performance data

Parameter	Value	Notes
Refrigerant	R134a	HFC, medium-pressure.
Nominal horsepower	0.36 HP ( $\approx 3/8$ HP)	Depending on rating condition HBP/CBP.
Cooling capacity	1077 W (HBP), 551 W (CBP)	At specified EN12900 conditions.
Power input	475 W (HBP), 339 W (CBP)	Single-phase operation.
Voltage / frequency	230 V, 50 Hz, 1-phase	Typical for water coolers 40-80 L.
Motor type	2-pole single-phase induction	Internally thermally protected.
Application group	High / Medium temperature (HBP / CBP)	Not suitable for low-temperature freezing.
Compressor cooling	Fan, about 350 ft <sup>3</sup> /min	Forced air cooling around shell.
Oil type / volume	POE, approx. 0.31 L	Pre-charged from factory.
Approx. internal free volume	2400 cm <sup>3</sup> (81.1 oz)	Without oil.

This **specification table** is essential for system designers who must match condenser size, evaporator load, and expansion device selection to the compressor envelope.

Using the correct voltage, frequency, and oil type is critical to preserve warranty and avoid early

motor or mechanical failure.

## Application examples and exploitation in the field

In practice, the KCE444HAG is commonly installed in:

- Water coolers between 40 and 80 liter nominal storage.
- Bottle coolers and small commercial beverage merchandisers operating in high or medium temperature ranges.

For water coolers, the compressor offers enough capacity to chill drinking water quickly while keeping energy consumption moderate, thanks to its roughly 475 W input at high-back-pressure conditions.

In bottle coolers, the wide evaporating envelope from negative temperatures up to more than +10°C allows flexible control of cabinet temperature without putting the compressor outside its design limits.

## Performance comparison with similar compressors

To understand the real value of the KCE444HAG, it is useful to compare it with another well-known R134a hermetic compressor such as the **GL90AA (ZMC EGL90AA)** widely used in domestic and light commercial refrigeration.

### Capacity and power comparison

Model	Refrigerant	Nominal HP	Cooling capacity (approx.)	Input power	Typical use
KCE444HAG	R134a	0.36 HP	1077 W (HBP), 551 W (CBP)	475 W (HBP)	Commercial water/bottle coolers.
EGL90AA (GL90AA)	R134a	0.25 HP	227 W (LBP)	-	Domestic refrigerators, small LBP cabinets.

From this table, the KCE444HAG clearly delivers a much higher **cooling capacity** than the EGL90AA, which translates into faster pull-down times and suitability for larger, more demanding systems.

However, the smaller EGL90AA consumes less power and is better suited where low-back-pressure, small-load operation is required, such as household fridges and compact freezers.

### Application temperature range comparison

Model	Application group	Evaporating temperature range
KCE444HAG	HBP / CBP	-17.8°C to +12.8°C.
EGL90AA	LBP	Around -35°C to -6.7°C in typical LBP charts.

The table shows why the KCE444HAG is chosen for positive temperature applications like water coolers, while the EGL90AA works better in freezer-type systems requiring lower evaporating temperatures.

Selecting the wrong compressor for the required evaporating range can lead to high discharge temperatures, low efficiency, and premature failure.

## Installation, reliability, and service considerations

The KCE444HAG compressor must be operated inside the condensing and evaporating temperature envelope defined by the manufacturer to guarantee long service life.

The datasheet specifies that performance values are valid only inside this envelope and also gives maximum allowable internal moisture and solid residue limits, emphasizing the need for clean, well-evacuated systems.

Technicians should:

- Use R134a only and charge with the correct POE oil volume if a major repair requires oil replacement.
- Keep the mounting angle within the 5° limit and respect guidelines for handling and disposal listed in the detailed product documentation.

Good airflow around the compressor and condenser, combined with properly sized capillary or expansion valve, keeps shell temperature and discharge pressure under control, further improving **reliability** in continuous water-cooler duty.

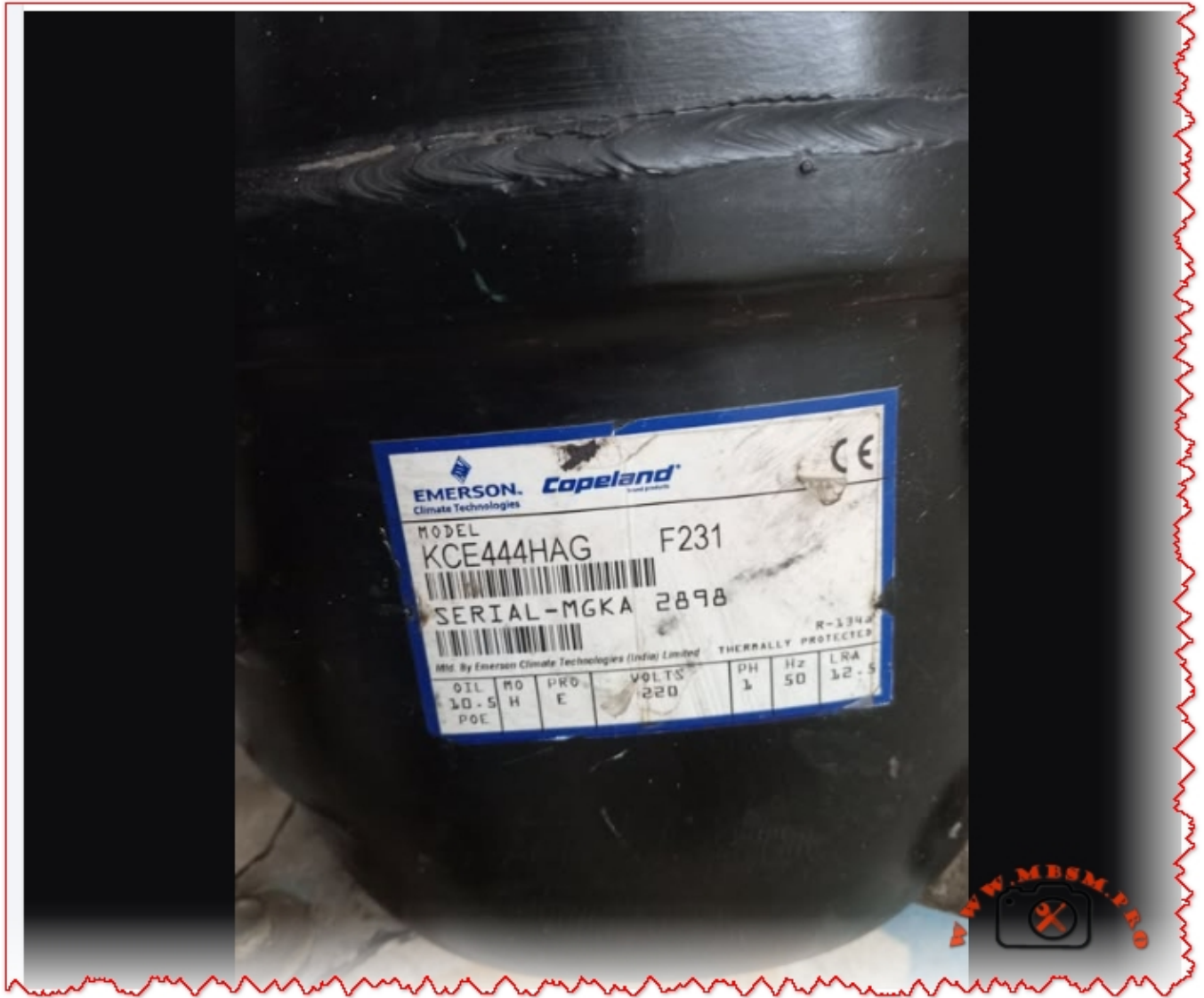

[kcl-compressorsDownload](#)

## Performance Nominals

High Back Pressure			Commercial Back Pressure								
Model	HP	Displacement cc per Rev	Capacity						Cooling Type (CFM)	Oil Charge Qty (cc)	Net Wt. (Kg.)
			7.2°C			-6.7°C					
			Btu/Hr.	kCal/Hr.	Watt	Btu/Hr.	kCal/Hr.	Watt			
<b>R134a, 50 Hz, 1 Phase</b>											
KCE419HAG	1/6	5.79	1585	399	465	860	217	252	Fan 350	310	10.2
KCN413CAG	1/6	6.15	-	-	-	1080	272	316	Fan 350	340	9.7
KCE425HAG	1/5	7.58	2145	540	629	1075	271	315	Fan 350	310	10.8
KCN416CAG	1/5	7.31	-	-	-	1380	338	392	Fan 350	340	9.7
KCE432HAG	1/4	9.42	2690	678	788	1330	332	390	Fan 350	310	11.8
KCE444HAG	3/8	12.05	3675	926	1077	1880	474	551	Fan 350	310	11.8
KC#444HAG	3/8	12.58	3700	932	1064	1720	433	504	Fan 350	890	20.2
KCN463HAG	1/2	15.33	5250	1323	1538	3130	789	917	Fan 350	380	11.5
KC#67HAG	1/2	18.27	5600	1411	1640	2830	713	829	Fan 350	890	21.0
KC#98HAG	3/4 +	25.91	8200	2066	2402	4100	1033	1201	Fan 350	890	21.5
<b>R134a, 60 Hz, 1 Phase 230 V</b>											
KCE432HAG	1/4	9.42	3225	813	944	1595	402	467	Fan 350	310	11.8
KCE444HAG	3/8	12.05	4275	1077	1252	2187	551	640	Fan 350	310	11.8
KCN463HAG	1/2	15.33	6300	1588	1845	3443	868	1008	Fan 350	380	11.5
KC#67HAG	1/2	18.27	6700	1688	1964	3120	786	914	Fan 350	890	21.0
KC#98HAG	3/4 +	25.91	9250	2330	2710	4633	1167	1358	Fan 350	890	21.5
<b>R134a, 60Hz, 115V</b>											
KCE444HAG	1/3	12.05	4200	1058	1231	2175	548	637	Fan 350 FM	310	11.8
<b>R22, 50 Hz, 1 Phase</b>											
KCE443HAE	1/3	8.00	3600	907	1054	1620	408	475	Fan 350	310	11.8
KCE461HAE	1/2	11.50	5100	1285	1494	2590	653	759	Fan 350	590	13.4
KC511HAE	1	18.27	9350	2356	2740	4210	1061	1234	Fan 350	905	21.5
KC513HAE	1 1/4	25.91	12800	3225	3749	6366	1604	1865	Fan 350	890	22.5
CR22K6M-PF1	1 1/2+	40.80	19000	4788	5563	8920	2248	2614	Fan 400	1330	29.8
CR30K6M-PF1	2 1/2	51.47	25000	6300	7330	12000	3024	3516	Fan 400	1330	32.5
CR36K6-PFZ	3	59.65	30100	7585	8814	14200	3578	4161	Fan 400	1330	34.9
CR42K6-PFZ	3 1/2	72.08	36100	9100	10570	17300	4360	5069	Fan 400	1330	34.9
<b>R22, 50 Hz, 3 Phase</b>											
CR22K6M-TFM	1 1/2+	40.80	18350	4633	5373	8260	2082	2420	Fan 400	1330	29.5
CR30K6M-TFM	2 1/2	51.47	24400	6161	7144	11600	2923	3399	Fan 400	1330	30.0
CR36K6-TF6	3	59.66	29900	7535	8755	14500	3654	4249	Fan 400	1330	31.0
CR42K6-TF5	3 1/2	72.09	35100	8845	10278	17200	4334	5040	Fan 400	1330	32.7
KCG554HAE	4 1/2	99.96	45000	11340	13185	-	-	-	Fan 420	2250	50.1
KCG562HAE	5	117.65	52000	13100	15236	-	-	-	Fan 420	2250	50.7
KCG572HAE	6	133.22	60000	15120	17580	-	-	-	Fan 420	2250	51.4
<b>R22, 60 Hz, 1 Phase</b>											
KCE461HAE	1/2	11.50	6100	1537	1788	3082	-	-	Fan 350	510	13.4
KC511HAE	1	18.27	10500	2646	3077	4210	1061	1234	Fan 350	905	21.5
KC513HAE	1 1/4	25.91	14500	3653	4247	6366	-	-	Fan 350	890	22.5
<b>R404A, 50 Hz, 1 Phase</b>											
KC#22CAL	1/4	8.00	-	-	-	1800	454	527	Fan 350	890	20.0
KC#38CAL	1/2	11.50	-	-	-	3200	807	937	Fan 350	890	21.5
KC#61CAL	3/4	18.27	-	-	-	5100	1285	1495	Fan 350	890	21.5
KC#84CAL	1	25.91	-	-	-	7000	1763	2052	Fan 350	890	22.5
KCM511CAL	1 3/8	40.80	-	-	-	9000	2268	2637	Fan 400	1330	29.8
KCM514CAL	1 3/4	51.47	-	-	-	12000	3025	3515	Fan 400	1330	32.5
KCM519CAL	2 3/8	59.65	-	-	-	16100	4057	4717	Fan 400	1330	34.9
KCM522CAL	2 3/4	72.08	-	-	-	18300	4610	5360	Fan 400	1330	34.9
<b>R404A, 50 Hz, 3 Phase</b>											
KCM519CAL	2 3/8	59.65	-	-	-	15800	3981	4630	Fan 400	1330	31.0
KCM522CAL	2 3/4	72.08	-	-	-	18300	4610	5360	Fan 400	1330	32.7

Note : KCM models can be used with R-134a



# Electrical Specifications

High Back Pressure

Commercial Back Pressure

Model	Power (W)	Current (A)	LRA (A)	Voltage Range	Motor Type	Start Capacitor (Mfd)	Run Capacitor (Mfd)	Relay		OLP
								Potential / PTC	Current	
<b>R134a, 50 Hz, 1 Phase</b>										
KCE419HAG	245	1.60	11	180-260	RSIR				KARP3627	TAE15/H3
KCN413CAG	180	0.84	10	180-260	CSCR	40/60	6	PTC-KCP14PO	KAT0411/H3	
	210	1.3	8.5	198-264	CSIR	40/60	-	-	KARP3141	TAE12/H3
KCE425HAG	360	2.50	13	180-260	CSIR	40/60	-	-	KARP4241	KAT0072/H3
KCN416CAG	220	1.00	10	180-260	CSCR	40/60	6	PTC-KCP14PO	KAT0413/H3	
KCE432HAG	375	2.80	12.5	180-260	CSIR	40/60			KARP4241	KAT0072/H3
KCE444HAG	475	2.20	13	180-260	CSCR	40/60	10	LT85002 OR PTC-KCP14PO		KAT0072/K3 OR T0072/K3
	575	3.20	16	198-264	CSIR	40/60	-	-	KARP4741	KAT0747/H3
KCJ44HAG	450	2.80	17	180-260	CSIR	80/100	-	-	KARP4841	MRT36ALX-112 OR KAT0159/B2
KCN463HAG	615	2.70	14	180-260	CSCR	80/100	15	LT85002		KAT0463/B2
KCJ#67HAG	675	3.85	23	180-260	CSIR	80/100			KARP5641	MRA12024-112 OR KAT0733/B2
KCJ#98HAG	975	5.90	32	198-264	CSIR	80/100		AC85001	-	MS-24-AJX-112 OR KAT0163/B2
<b>R134a, 60 Hz, 1 Phase</b>										
KCE432HAG	470	2.75	12.5	207-253	CSIR	40/60		-	KARP4241	KAT0072/H3
KCE444HAG	550	2.35	13	207-253	CSCR	40/60	10	PTC-KCP14PO		KAT0072/K3 OR T0072/K3
	550	2.35	16	207-253	CSCR	40/60	10	LT85002		
KCN463HAG	810	3.65	14	197-253	CSCR	80/100	15	LT85002		KAT0463/B2
KCJ#67HAG	820	4.20	23	198-242	CSIR	80/100	-		MTRP5941	KAT0733/B2
KCJ#98HAG	1120	6.10	28	207-253	CSIR	80/100	-	AC85001	-	KAT0167/B2
<b>R134a, 60Hz, 115v</b>										
KCE44HAG	600	6.9	27	103-127	CSIR	150/200	-	-	MTRPH-6241	KAT0166/H3
<b>R22, 50 Hz, 1 Phase</b>										
KCE443HAE	475	2.30	13	180-260	PSC/CSCR*	40/60*	10	LT85002*		KAT0072/K3 OR KAT 0159/B2
KCE461HAE	675	3.10	17	180-260	PSC/CSCR*	60/80*	15	LT85003*		KAT0159/B2
KCJ511HAE	1020	4.70	25	180-260	PSC/CSCR*	80/100*	25	LT85002*		INTERNAL
KCJ513HAE	1440	6.80	30	180-260	PSC/CSCR*	80/100*	36	AC85001*		INTERNAL
CR22K6M-PF1	1750	7.20	44	180-260	CSCR*	80/100*	36	AC85004*		INTERNAL
CR30K6M-PF1	2350	11.00	72	180-260	PSC/CSCR*	150/200*	45	AC85001*		INTERNAL
CR36K6-PFZ	2720	13.60	85	198-264	CSCR	130/156 OR	40 OR	AC85004	-	INTERNAL
						120/150	45			
CR42K6-PFZ	3240	15.40	104	198-264	CSCR	189/227 OR	60 OR	AC85005	-	INTERNAL
						150/200	65			
<b>R22, 50 Hz, 3 Phase</b>										
CR22K6M-TFM	1750	3.20	20	342-462	3PH	-	-	-	-	INTERNAL
CR30K6M-TFM	2275	4.20	28	342-462	3PH	-	-	-	-	INTERNAL
CR36K6-TF6	2680	4.90	41	360-460	3PH	-	-	-	-	INTERNAL
CR42K6-TF5	3300	6.10	45	340-460	3PH	-	-	-	-	INTERNAL
KCG554HAE	4450	7.20	44	360-460	3PH	-	-	-	-	INTERNAL
KCG562HAE	5250	8.50	49	360-460	3PH	-	-	-	-	INTERNAL
KCG572HAE	6100	10.20	55	360-460	3PH	-	-	-	-	INTERNAL
<b>R22, 60 Hz, 1 Phase</b>										
KCE461HAE	740	3.3	21	207-253	CSCR	60-80	15	LT85003	-	T0733/B9
KCJ511HAE	1175	5.30	23	197-253	CSCR	80/100	25	LT85002	-	INTERNAL
KCJ513HAE	1720	7.9	36	207-253	PSC/CSCR	80/100	36	AC85001	-	INTERNAL



## Company Profile



▲ Karad Plant



▲ Atit Plant



▲ Computer Aided Engineering Facility

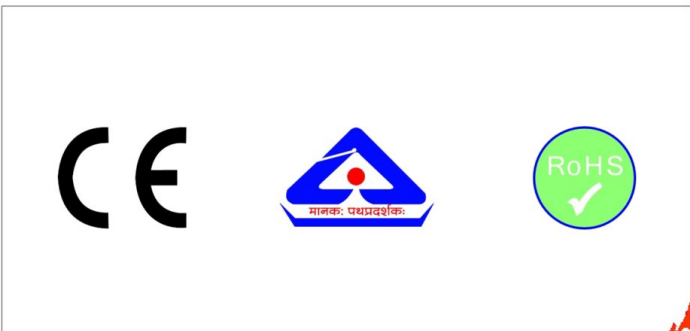

▲ Product Approvals

Emerson is a global company that brings together technology and engineering to provide innovative solutions for our customers in a wide range of industrial, commercial, and consumer markets. Our priority is to design, produce and deliver products, systems, and solutions that make people's lives better.

Emerson Climate Technologies (India) Limited is offering innovative, energy efficient, environment friendly and reliable compressors to a broad range of customers across India and overseas, for the last four decades.

Fractional and Integral Horse Power compressors provide perfect cooling, creating value for its users. The compressors are manufactured in Karad and Atit Plants, which have state-of-the-art facilities and acclaimed to have "Gold Rating" under Emerson's Plant Technology Franchise Standards.

The performance of the compressors is optimized using CAE facilities. The components are sourced internationally and have been subjected to stringent Qualification Standards of Emerson Climate Technologies. The performance of compressors is validated by testing in a suitable appliance at an ambient of 46°C.

The countrywide Sales and Service network of Emerson Climate Technologies (India) Limited, is positioned to provide prompt service to our customers.



# Refrigeration Product Catalogue

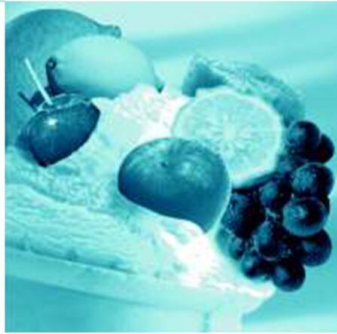

**Copeland**<sup>®</sup>  
brand products

**EMERSON**  
Climate Technologies

EMERSON. CONSIDER IT SOLVED.



Copeland KCE444HAG hermetic compressor mbsmpro



#### Ahmedabad

Emerson Climate Technologies (India) Ltd.  
3, Jayantilal Park, Near Heera Rupa Hall,  
Ambli-Bhopal Road  
Ahmedabad - 380 058  
Gujarat  
India  
Tel: (91-79) 2692 6648/ 2692 6649  
Fax: (91-79) 2692 2321

#### Bangalore

Emerson Climate Technologies (India) Ltd.  
No.21, K.H.Road  
Bangalore 560 027  
Karnataka  
India  
Tel : (91-80) 2222 0327  
Fax : (91-80) 2227 6280

#### Chennai

Emerson Climate Technologies (India) Ltd.  
New No.10, Postal Colony II street  
West Mambalam  
Chennai 600 033  
Tel : (91-44) 2371 8771/8772/8773  
Fax : (91-44) 2371 8979

#### Faridabad

Emerson Climate Technologies (India) Ltd.  
3B-3B.P, NIT  
Faridabad 120 001  
Haryana  
Tel : (91-129) 2414581 , 2431037

#### Registered Head Office

Emerson Climate Technologies (India) Limited  
1202/1, Ghole Road, Pune 411 004  
Tel: (91-20) 25534988/998, Fax: (91-20) 25536350

#### Plants

Karad - Dhebewadi Road, Karad - 415 110, Maharashtra  
Tel: (91-2164) 241413 / 241002, Fax: (91-2164) 241122

Atit - Atit Pali Road, Atit - 415 519, Maharashtra  
Tel: (91-2162) 262068 / 262077, Fax: (91-2162) 262069

#### Kolkotta

Emerson Climate Technologies (India) Ltd.  
35/7, Tollygunje Circular Road  
P.S.New Alipore  
Kolkotta 700 053  
West Bengal  
India  
Tel: (91-33) 2400 2779/2400 2781  
Fax: (91-33) 2400 2784

#### Mumbai

Emerson Climate Technologies (India) Ltd.  
Unit No. 4, 5, 6 & 7, Bhaveshwar Arcade  
LBS Marg, Opp. Shreyas Cinema  
Ghatkopar (West)  
Mumbai 400 086  
Maharashtra  
India  
Tel: (91-22) 2500 6630/ 2500 6632  
Fax: (91-22) 2500 6570

#### New Delhi

Emerson Climate Technologies (India) Ltd.  
56, Rama Road Industrial Area  
Nr. Mahindra Showroom  
New Delhi 110 015  
India  
Tel: (91-11) 2511 1861/1862/1863/1864  
Fax: (91-11) 2545 7748

#### Pune

Emerson Climate Technologies (India) Ltd.  
Shop No. 1,2,3,6,7,8  
S.No.55, Katraj Dehu Bypass Road  
Vadgaon Budruk  
Pune 411 041, India  
Tel: (91-20) 24351401  
Fax: (91-20) 24351501

#### Secunderabad

Emerson Climate Technologies (India) Ltd.  
1141, Rashtrapathi Road  
Nr. Sree Gujarati Seva Mandal  
Secunderabad 500 003  
Andhra Pradesh  
India  
Tel : (91-40) 2753 0834/0835, 5526 0411  
Fax: (91-40) 2753 0832

As we are constantly endeavoring to improve the performance of our models, the specifications mentioned here are subject to change from time to time.  
The Emerson logo is a trademark and a service mark of Emerson Electric Co.

Refrigeration Catalogue 010808

EMERSON. CONSIDER IT SOLVED.



Copeland KCE444HAG hermetic compressor mbsmpro

# Emerson Climate Technologies' Best Practices Guide

## System Cleanliness

- It is absolutely necessary that all impurities / contamination like moisture, burr, cleaning agent and chemicals are removed from the system before operation in order to avoid compressor failures.
- All system components have to be de-hydrated and should be Nitrogen charged till they are taken for assembly. Use bright annealed refrigeration grade Copper tubes.
- Use tri-chloro Ethylene for flushing followed by dry air or Nitrogen to remove the trace of tri-chlo Ethylene.

## Brazing

- While brazing all the joints purge low pressure Nitrogen through the tube. This will avoid internal oxidation and formation of contamination. Use adequate amount of flux while brazing.
- The joints have to be free from oil and grease before brazing. For Copper to Copper joints use phosphorous Copper as brazing alloy and Copper - Silver for Copper to Steel joints. Oxy Acetylene is best suited for brazing.

## Leak Testing

- The system has to be adequately pressurized with dry air or Nitrogen.
- Use of electronic leak detectors is the best way to detect leaks.
- Conventional methods of checking the leaks can also be used.
- Do not pressurize the system with air and R134a.

## Evacuation

Effective evacuation of the system ensures removal of moisture. For achieving desired vacuum level of 200 microns:

- Pull vacuum from both sides
- Heat the system with bulbs or infra red lamps
- Use Copper tubes to connect the vacuum pump and the system
- The connecting Copper tubes have to be short in length and bigger in diameter
- Use adequately sized two stage rotary vacuum pump having anti-suckback provision
- Use electronic vacuum gauge to measure the vacuum level
- Never use a hermetic compressor for evacuation. It is not meant for evacuation and cannot achieve desired vacuum level

## Refrigerant Charging

- Quality and quantity of refrigerant immensely influences the performance and reliability of any refrigeration system.
- Refrigerant should be procured from genuine source. Use digital weigh balance during refrigerant charging.
- Maintain a separate set of hoses, tubes, valves for different refrigerants. Do not use anti-choke as it damages the compressor.
- Use pressure temperature chart of refrigerant for achieving optimum system performance.

## Compressor Mounting

- Torque the nut adequately and ensure that the washer / bolt head rest on the sleeve and not on the rubber grommet.
- The suction and discharge piping should be properly looped to avoid vibrations and refrigerant leakages. The compressor should not be held rigidly by any means.
- These compressors are not suitable for mobile applications.

## Electricals

- Always check the voltage across C & R terminals. Voltage at this point should fall within the prescribed operating voltage range. If the supply voltage conditions are poor, use appropriately sized voltage stabilizer with low, high voltage cutout and On-delay timer.
- Always use genuine electrical accessories supplied by Emerson Climate Technologies.
- Earthing the appliance is necessary from the safety stand point.
- All electrical joints have to be firm and properly insulated.

## Attending The Field Complaints

Verify the field complaint based on facts and observations made through use of proper tools and equipment. Rule out all the possibilities before replacing the compressor. Analyze the compressor independently for its proper functioning.

Removing of compressor from the system without understanding the root cause will lead to another compressor failure.



### CR36 / CR42

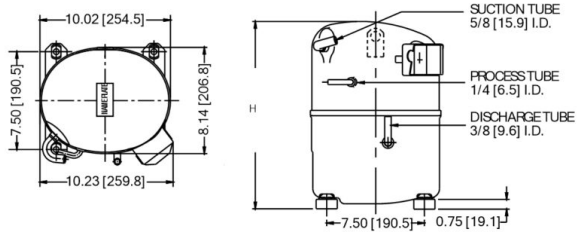

Model	Suction ID	Discharge ID	Height (mm)
CR36K6-PFZ	5/8"	3/8"	371.5
CR36K6-TF6	5/8"	3/8"	365.2
CR42K6-PFZ	3/4"	3/8"	384.2
CR42K6-TF5	3/4"	3/8"	384.2

### KCG

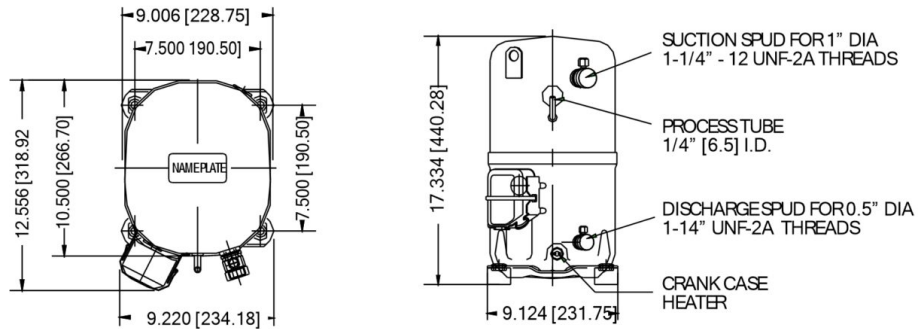

### KCM

KCM 511CAL/KCM514CAL

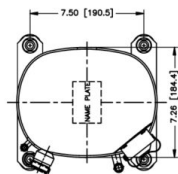

KCM 519CAL/KCM522CAL

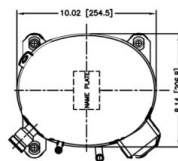

Model	Suction Spud	Discharge ID	Height (mm)
KCM511CAL	Ø0.750 1-14 UNS2A Rolled Threads	3/8"	361.0
KCM514CAL	Ø0.625 1 1/4 12UNF 2A Rolled Threads	3/8"	360.0
KCM519CAL	Ø0.625 1 1/4 12UNF 2A Rolled Threads	3/8"	371.5
KCM522CAL	Ø0.625 1 1/4 12UNF 2A Rolled Threads	3/8"	384.2

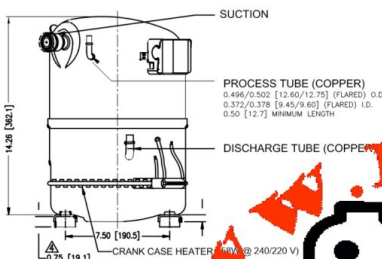
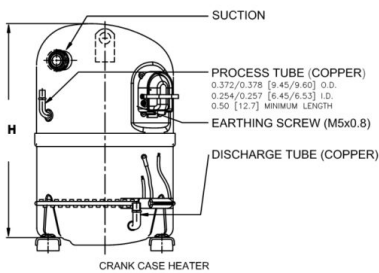

## Wiring Diagrams

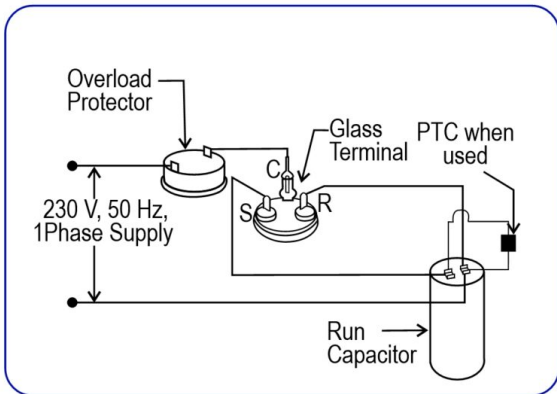

**PERMANENT SPLIT CAPACITOR (PSC)**

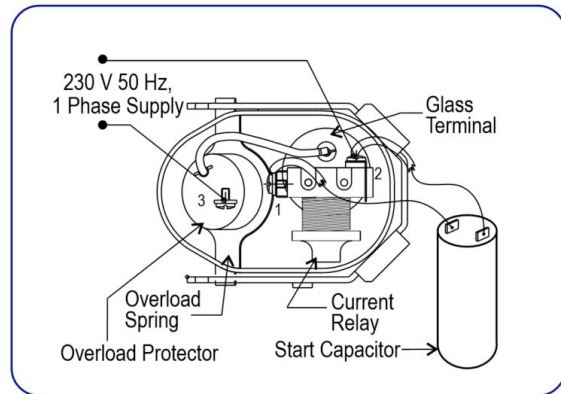

**CAPACITOR START INDUCTION RUN (CSIR) WITH PLUG-IN START RELAY**

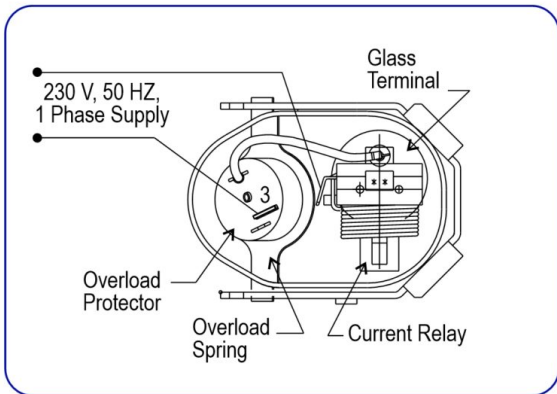

**RESISTANCE START INDUCTION RUN (RSIR) WITH PLUG-IN START RELAY**

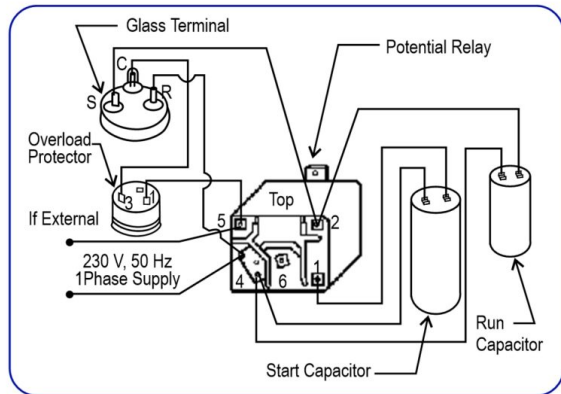

**CAPACITOR START CAPACITOR RUN (CSCR)**

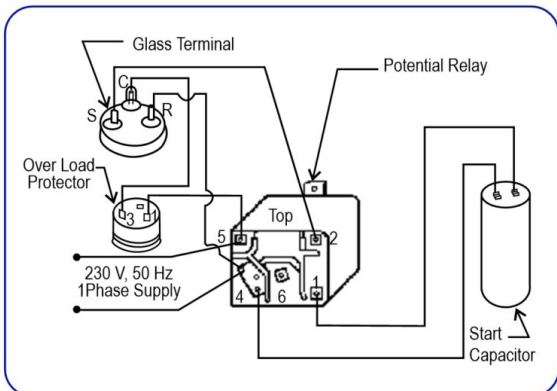

**CAPACITOR START INDUCTION RUN (CSIR)**



## Dimensional Drawings

### KCE

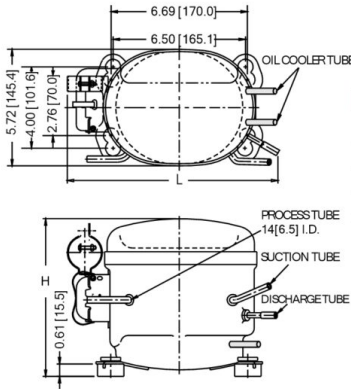

Model	Suction ID		Discharge ID		L	H	Oil Cooler Tube		Capacitor Mounting Bracket Provision
	inch	mm	inch	mm			inch	mm	
R134a High Back Pressure									
KCE419HAG	1 / 4	6.5	1 / 4	6.5	253	196	—	—	No
KCE425HAG	1 / 4	6.5	1 / 4	6.5	257	196	—	—	Yes
KCE432HAG	5 / 16	8.0	1 / 4	6.5	257	212	—	—	Yes
KCE444HAG	5 / 16	8.0	1 / 4	6.5	253	212	—	—	No

### KCE461HAE

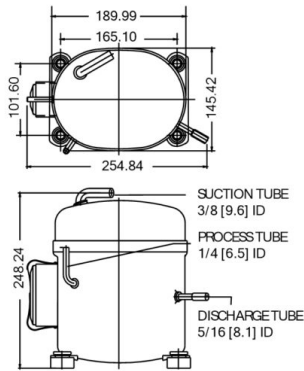

### KCE443HAE

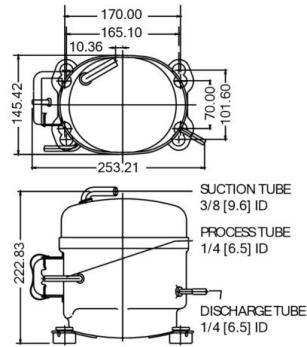

### KCN

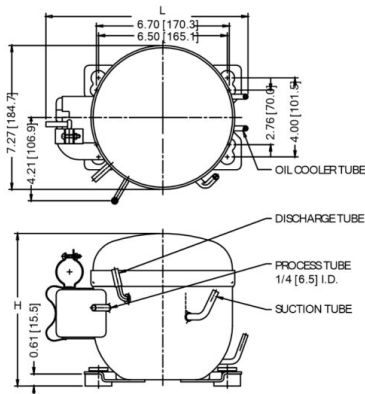

Model	Suction ID		Discharge ID		L	H	Oil Cooler Tube		Capacitor mounting
	Inch	mm	inch	mm			inch	mm bracket Provision	
KCN372LAG	1 / 4	6.5	1 / 4	6.5	259	189	3 / 16	4.9	NO
KCN396LAG	1 / 4	6.5	1 / 4	6.5	259	196	3 / 16	4.9	YES
KCN411LAG	5 / 16	8.0	5 / 16	8.0	250	202	—	—	YES
KCN415LAG	5 / 16	8.0	5 / 16	8.0	250	202	—	—	YES
KCN463HAG	5 / 16	8.0	5 / 16	8.0	244	202	—	—	YES
KCN413CAG	1 / 4	6.5	1 / 4	6.5	244	189	—	—	YES
KCN416CAG	1 / 4	6.5	1 / 4	6.5	244	189	—	—	YES



## Guidelines For Achieving Optimum Appliance Performance

### Deep Freezer

- Evaporator circuit should be bottom to top
- Minimum 75mm PUF insulation
- Capillary to suction line heat exchanger of 6" improves the performance

### Walk-in Cooler

- Proper heat load should be estimated for selecting number of systems.
- Adequate wall and floor insulation with ante room to be provided.
- Initial pull down time will range from 18 to 24 hrs.
- Hot gas defrost method should not be used.
- Use proper capacity strip heaters placed equidistant across the width of evaporator coil.

### Softy Ice-cream Machine

- Precooling of softy mix to 4° C should be achieved through separate refrigeration system.
- Compressor cycling should not exceed 6 cycles.

### Ice Candy

- Use suction line accumulator of 3" dia x 8" height having oil return orifice.
- Evaporator feeding from bottom to top.
- Use stirrer in brine tank for brine circulation to achieve uniform brine temperature.
- Correct %mix of brine and water is important to achieve desired brine temperature.
- -20° C of brine temperature will ensure 20 minute batch time of hard candies.

*Copeland Brand Products are used for several other applications. Above guidelines are apart from system design details. For details contact nearest Emerson Climate Technologies (India) Limited office.*

## Notes

1. Electrical rating is 230 V, 50 Hz and 230 V, 60 Hz for single phase models and, 400 V, 50 Hz for three phase models.
2. Operating voltage range signifies the range of voltage for which the compressor can start and run up to 43°C ambient.
3. Cooling capacity and power consumption are nominal values at specified rating conditions and subject to ±5% variation.
4. Direct air flow on glass terminal cover should be avoided.
5. Compressors with CSIR, CSCR circuit and three phase models may be used with thermostatic expansion valve.
6. Compressors with RSIR Circuit must use capillary tube only.
7. All compressors use two pole motors.
8. Compressors for specific applications are rated for IS-10617 Part I and Part III-1983.
9. All run capacitor should have a rating of 440 VAC and start capacitor 275 VAC surge, unless otherwise specified by Emerson Climate Technologies (India) Limited.

## Useful Conversions

### Pressure

1 micron	= 0.001 mm
0.1 mm Hg	= 100 microns
1 mm Hg	= 1 Torr
1 kg / cm <sup>2</sup>	= 14.223 psig
1 bar	= 14.504 psig
1 bar	= 1.0197 kg/cm <sup>2</sup>

### Temperature

°F = 1.8 x °C + 32

### Volume

1ft <sup>3</sup>	= 28.3 Liters
1ft <sup>3</sup>	= 0.0283 meter <sup>3</sup>
1 metre <sup>3</sup>	= 35.315 ft <sup>3</sup>
1 metre <sup>3</sup>	= 1000 Liters
1cc	= 1 milliliter
1 oz	= 29.57 milliliter

### Energy

Watt / hr x 0.8598	= kcal/hr
Watt / hr x 3.413	= Btu/hr
1 ton	= 12000 Btu/hr
1 kilojoule	= 0.95 Btu
kcal/hr x 3.968	= Btu/hr

### Area

1ft <sup>2</sup>	= 0.0929 metre <sup>2</sup>
1metre <sup>2</sup>	= 10.758 ft <sup>2</sup>

### Distance

1 inch	= 25.4 mm
1 ft	= 12 inch
1 meter	= 3.28 foot
1 meter	= 39.36 inch
1 yard	= 36 inch

### Weight

1ton	= 1000 kg
1 kg	= 2.2 pounds (lb)

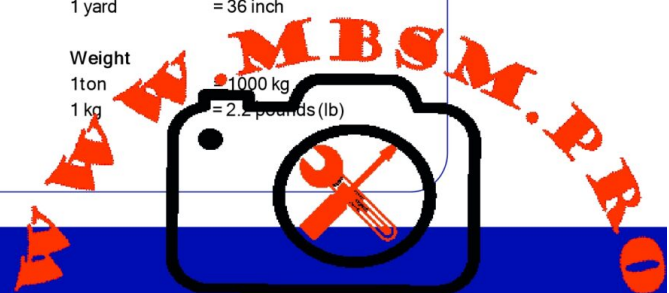

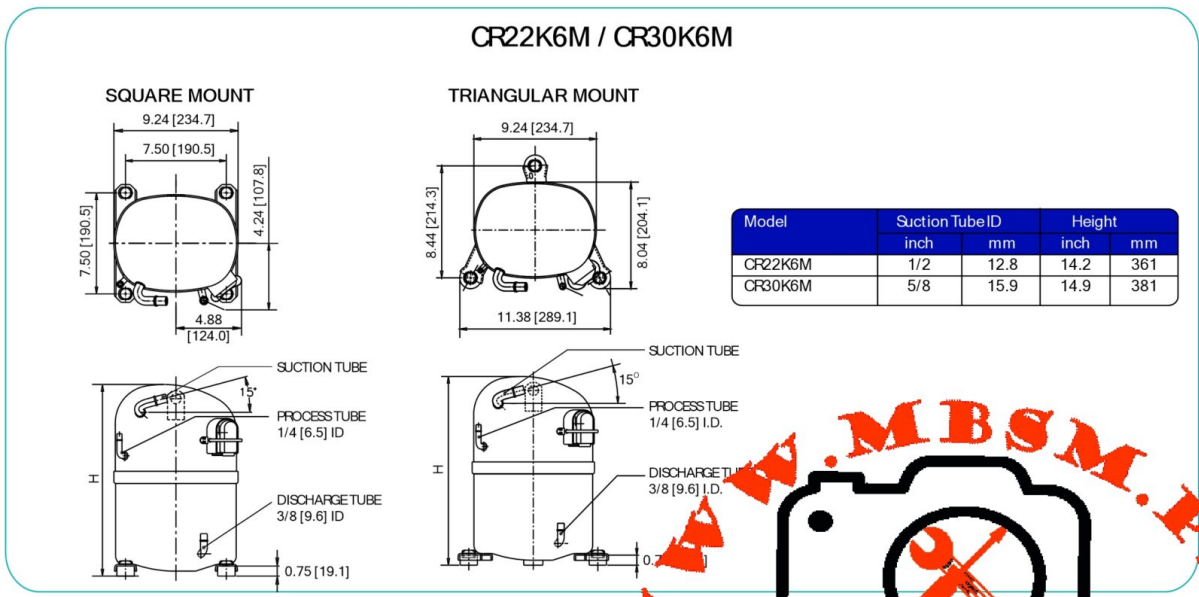
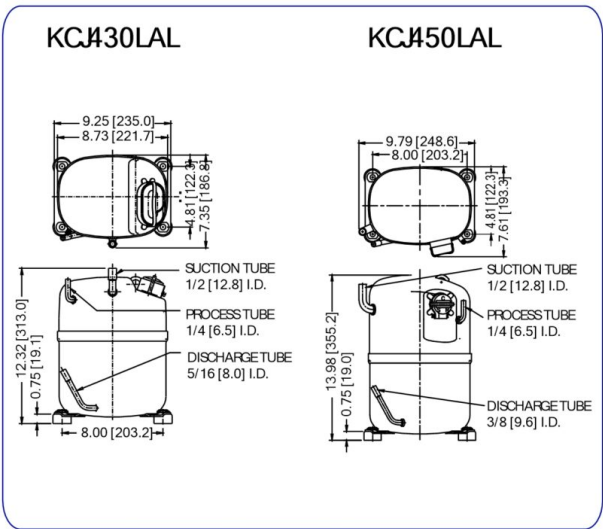
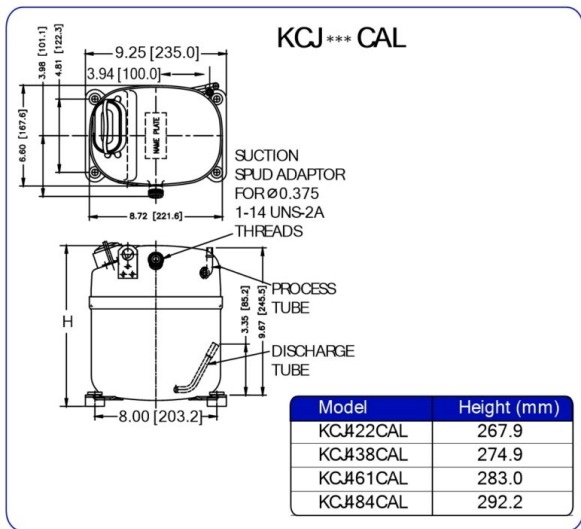
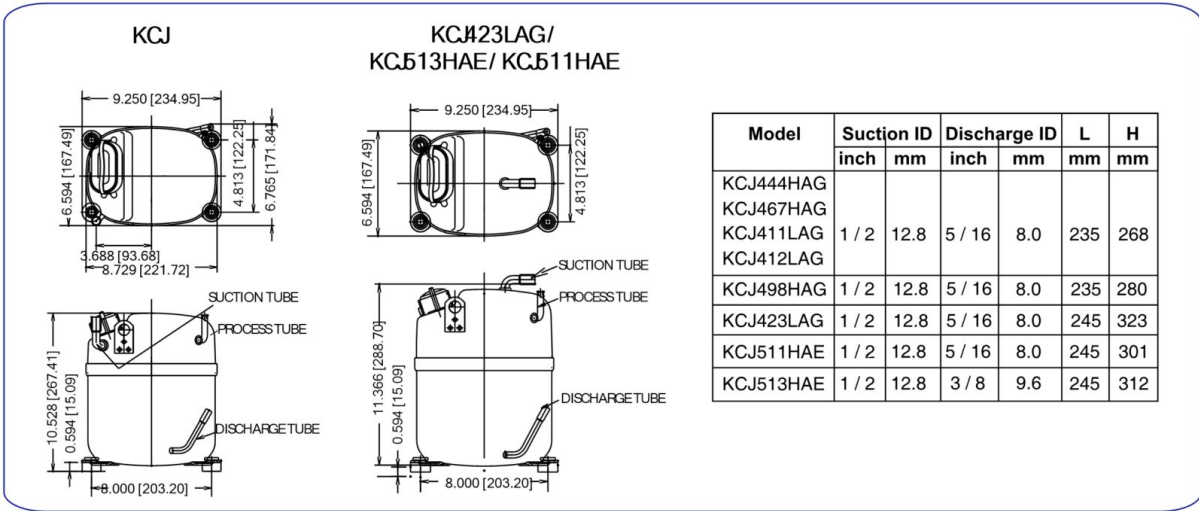

## KCX Series Compressor Nomenclature

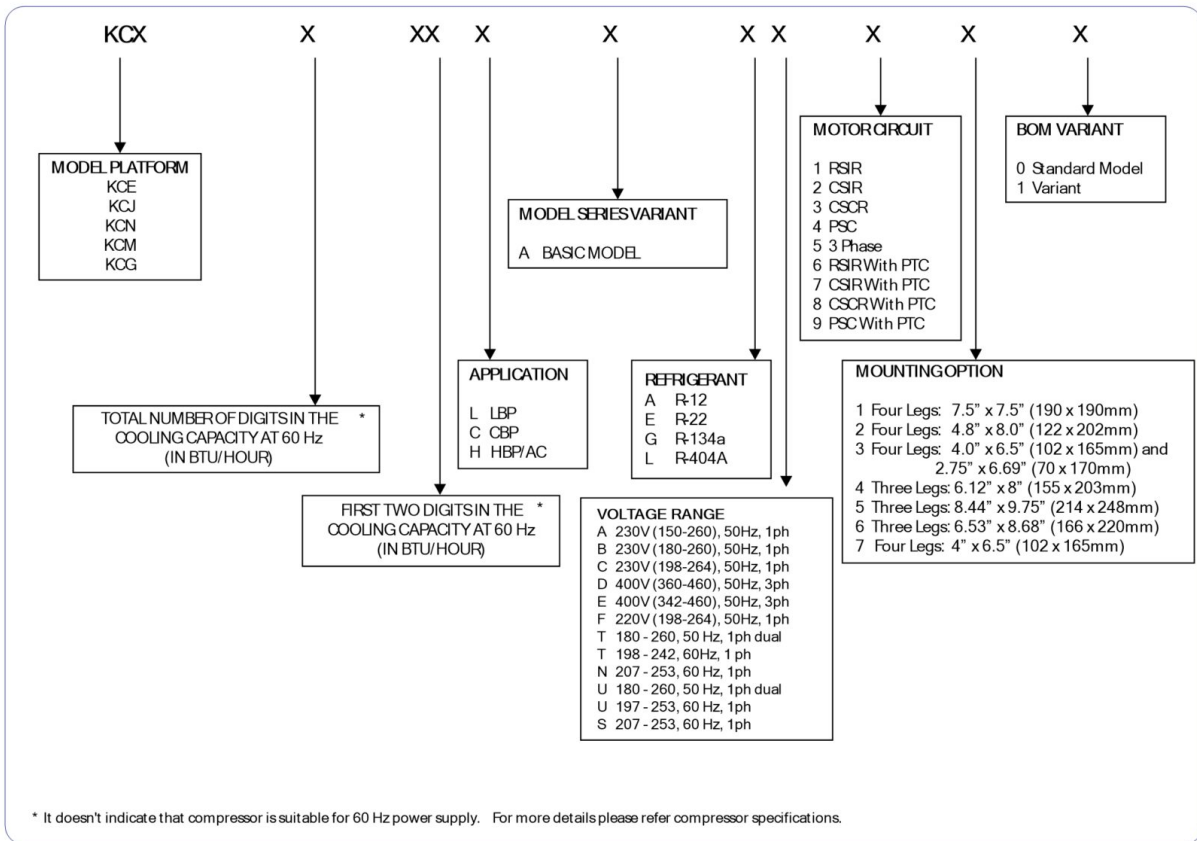

## CR6 Series Compressor Nomenclature

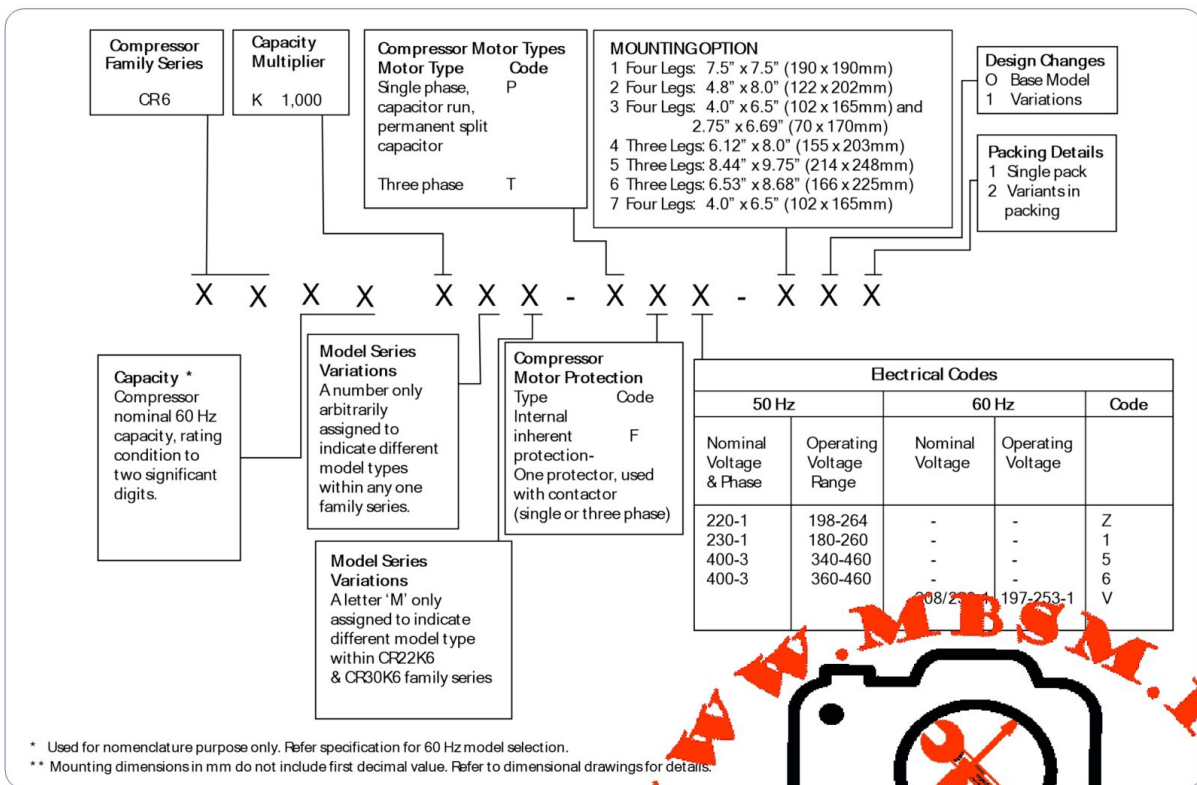



## Electrical Specifications

High Back Pressure

Commercial Back Pressure

Model	Power (W)	Current (A)	LRA (A)	Voltage Range	Motor Type	Start Capacitor (Mfd)	Run Capacitor (Mfd)	Relay		OLP
								Potential / PTC	Current	
<b>R404A, 50 Hz, 1 Phase</b>										
KC#22CAL	400	2.40	16	180-260	CSIR	80/100	-	-	KARP4741	KAT0463/B2
KC#38CAL	625	3.70	24	180-260	CSIR	80/100	-	-	KARP5641/ MTRP5641	T0732/B2
KC#61CAL	925	4.50	25	180-260	CSCR	80/100	25	LT85002	-	INTERNAL
KC#84CAL	1250	6.20	37	180-260	CSCR	80/100	25	AC85001	-	INTERNAL
KCM511CAL	1385	6.30	54	180-260	CSCR	80/100	36	AC85004	-	INTERNAL
KCM514CAL	1840	8.70	72	180-260	CSCR	150/200	45	AC85001	-	INTERNAL
KCM519CAL	2360	12.30	85	180-260	CSCR	130/156 OR 120/150	40 OR 45	AC85004	-	INTERNAL
KCM522CAL	2600	12.00	104	180-260	CSCR	189/227 OR 150/200	60 OR 65	AC85005	-	INTERNAL
<b>R404A, 50 Hz, 3 Phase</b>										
KCM519CAL	2325	4.70	41	342-460	3PH	-	-	-	-	INTERNAL
KCM522CAL	2600	5.20	45	342-460	3PH	-	-	-	-	INTERNAL

### Low Back Pressure

Model	Power (W)	Current (A)	LRA (A)	Voltage Range	Motor Type	Start Capacitor (Mfd)	Run Capacitor (Mfd)	Relay		OLP
								Potential / PTC	Current	
KCE34LAG	110	1.1	9	150-260	RSIR	-	-	-	KARP2827	TAE7/H3
KCE345LAG	135	1.2	9	180-260	RSIR	-	-	-	KARP3227	TAE7/H3
KCN372LAG	159	1.34	10	180-260	CSIR	40/60	-	-	KARP3141	TAE15/H3
	159	1.34	11	180-260	RSIR	40/60	-	-	KARP3227	TAE15/H3
KCN396LAG	205	1.85	10	180-260	CSIR	40/60	-	-	KARP4141/MTRP14141	TAE15/H3
KCN411LAG	245	2.10	10	180-260	CSIR	40/60	-	-	KARP4241 OR MTRP4241	KAT0072/H3
	245	2.10	10	180-260	RSIR	-	-	KCP15-RO	-	KAT0072/H3
KC#11LAG	280	2.20	22	180-260	CSIR	80/100	-	-	KARP4841	KAT0159/B2
KC#12LAG	310	2.75	24	180-260	CSIR	80/100	-	-	KARP5641	KAT0159/B2
KCN415LAG	325	2.00	14	180-260	CSCR	80/100	10	LT85002	-	KAT0072/B2
KC#23LAG	485	3.00	30	198-264	CSCR	150/200	10	LT85003	-	KAT0732/B2
<b>R404A, 50Hz, 1 Phase</b>										
KCN414LAL	325	2.3	16	180-260	CSIR	60/80	-	-	KARP4241	KAT0072/H3
KCN418LAL	375	2	14	180-260	CSCR	80/100	10	LT85002	-	KAT0072/B2
KCN422LAL	455	2.22	16	180-260	CSCR	80/100	15	LT85003	-	KAT164/B2
KC#30LAL	580	3.2	30	180-260	CSCR	150/200	10	LT85003	-	INTERNAL
KC#50LAL	975	5	50	180-260	CSCR	150/200	25	AC85004	-	INTERNAL

\* These are optional Accessories to be used for CSCR Circuit

